

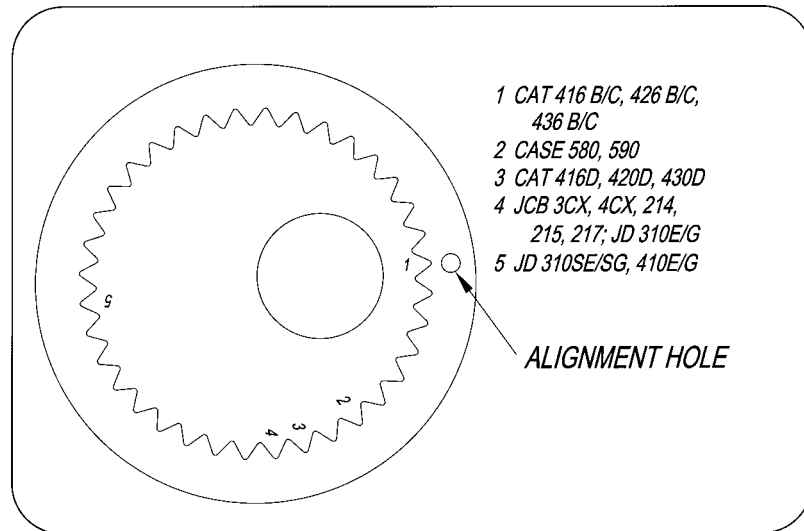

711 Lake Street
Kent, Ohio 44240

Phone: (330) 673-5826
Fax: (330) 677-1616
Company Headquarters: (800) 527-2282
West Coast Warehouse: (800) 624-1616

TLB BREAKER SWITCH HITCH™ ADJUSTMENT



- STEP 1** Remove the large snap ring from the outer edge of the rotating boss.
(Refer to the illustration.)
- STEP 2** Press on the outside of the boss so that the indexing teeth disengage from the toothed ring on the side plate.
- STEP 3** Rotate the boss and align the appropriate index number with the alignment hole in the plate, and press the boss into position so that its teeth engage fully with those in the outer ring.
- STEP 4** Reinstall the snap ring in the outer groove of the rotating boss, and repeat Steps 1 through 4 on the other side plate boss.

Please note that only the RIGHT hand rotating boss has the weldment for the keeper bolt. Although both bosses are otherwise similar, they must not be exchanged for one another if the index points are to be correct.

Although there are only five positions marked on the indexing boss, any one of the nineteen positions between index mark "1" and mark "5" can be used. Refer to the chart on the facing page to determine which index location is needed to set the pin center-to-center needed. Unless otherwise requested, Kent will ship all SWITCH HITCH™ hammers at position "2" for the 14" center-to-center distance.



TLB BREAKER SWITCH HITCH™ ADJUSTMENT

